

OBT_MECH

Ticket parking and invalidating module

USER AND MAINTENANCE MANUAL

MANUFACTURED BY

ADEL S.r.l.

Registered office: Via Saffi, 58

Operational office: Via Nonantolana, 970/1

41100 MODENA

Tel. 059-2550137 Fax 059-2551207

e-mail adel@adel2000.it

REVISION

| DATE | AUTOR | VER. | CHANGES |
|-------------|--------------|-------------|----------------|
| | | | |
| | | | |
| | | | |

INDEX

| | | |
|-----|--|---|
| 1 | GENERALITIES..... | 4 |
| 2 | INSTALLATION..... | 4 |
| 3 | CONNECTIONS..... | 4 |
| 3.1 | CN 1 INTERFACE CONNECTOR..... | 4 |
| 3.2 | CN 2 INTERFACE AND POWER SUPPLY CONNECTOR..... | 4 |
| 3.3 | CN 3 PARK SOLENOID CONNECTOR..... | 4 |
| 3.4 | CN 4 DEFLECTOR SOLENOID CONNECTOR..... | 4 |
| 3.5 | CN 5 SOLENOID DEVIATOR CONNECTOR..... | 5 |
| 3.6 | CN 6 TICKET MOTOR CONNECTOR..... | 5 |
| 4 | DIMENSIONS OF SUBUNIT OBT_MECH..... | 6 |
| 5 | DIMENSIONS ENC899 + OBT_MECH..... | 7 |

1 GENERALITIES

The OBT_MECH subunit is one of the accessories of the ENC899 module that allows a full management of two titles, a ticket and a plastic card.

The module allows to park a ticket and manage the card and execute the payment procedures, reload the ticket from parking, validate it magnetically, print and give back to the user or swallow it. The mechanical validation is done during swallowing of the title.

2 INSTALLATION

To combine the ENC899 and OBT_MECH modules simply place them together and fasten them with two M3x6TC screws.

The motion of the ENC899 module is generated by an idling gear located in the rear part of the ENC899 and a coaxial gear with a rubber idler wheel located in the front part of the OBT_MECH module.

3 CONNECTIONS

3.1 CN 1 INTERFACE CONNECTOR

This connector has some of the control signals coming from the ENC899 CPU card.

The pin layout of CN1 (JST PH 4x1 PM 90°) is the following:

Pin 1 FD 4
Pin 2 FD 5
Pin 3 FD 6
Pin 4 FD 7

3.2 CN 2 INTERFACE AND POWER SUPPLY CONNECTOR

This connector has other control signals and supplies coming from the ENC899 module CPU card.

The pin layout of CN2 (JST PHD 2x5 PM 90°) is the following:

| | | | |
|-------|------|--------|------|
| Pin 1 | FD 0 | Pin 2 | FD 1 |
| Pin 3 | FD 2 | Pin 4 | FD 3 |
| Pin 5 | Vcc | Pin 6 | Vcc |
| Pin 7 | GND | Pin 8 | GND |
| Pin 9 | Vdd | Pin 10 | Vdd |

3.3 CN 3 PARK SOLENOID CONNECTOR

In this connector is present the command for the starting solenoid of the roller counterpart that allows to manage the passage of tickets and cards from and to the ENC899 module:

The pin layout of CN3 (JST PH 2x1 PM 90°) is the following:

Pin 1 VDD
Pin 2 Coil Prc

3.4 CN 4 DEFLECTOR SOLENOID CONNECTOR

In this connector is present the solenoid command to activate the deflector present in the parking section, it is necessary in order park a plastic card instead of a paper ticket. The deflector in resting position enables parking of the ticket, it must be activated in order to park a card.

The pin layout of CN4 (JST PH 2x1 PM 90°) is the following:

Pin 1 VDD
Pin 2 Dev coil

3.5 CN 5 SOLENOID DEVIATOR CONNECTOR

In this connector is present the command for the solenoid to activate counterpart roller that allows to manage parking and swallowing of the card

The pin layout of CN5 (JST PH 2x1 PM 90°) is the following:

Pin 1 VDD
Pin 2 Card coil

3.6 CN 6 TICKET MOTOR CONNECTOR

In this connector is present the command to start the motor that takes the ticket to the parking position and that allows reloading or swallowing.

The pin layout of CN6 (JST PH 2x1 PM 90°) is the following:

Pin 1 Mot Prk1
Pin 2 Mot Prk2

4 DIMENSIONS OF SUBUNIT OBT_MECH

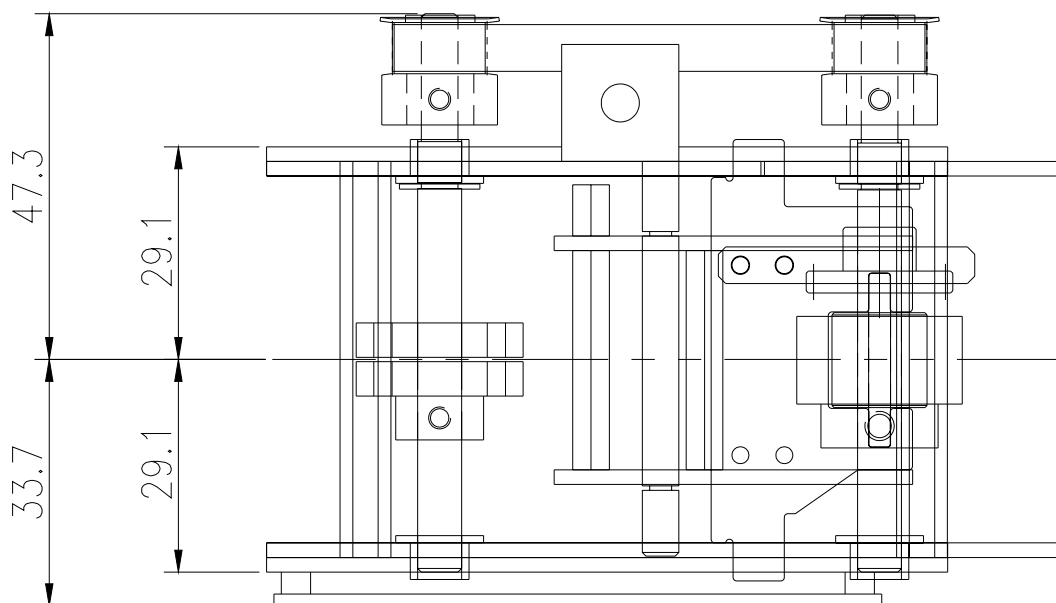
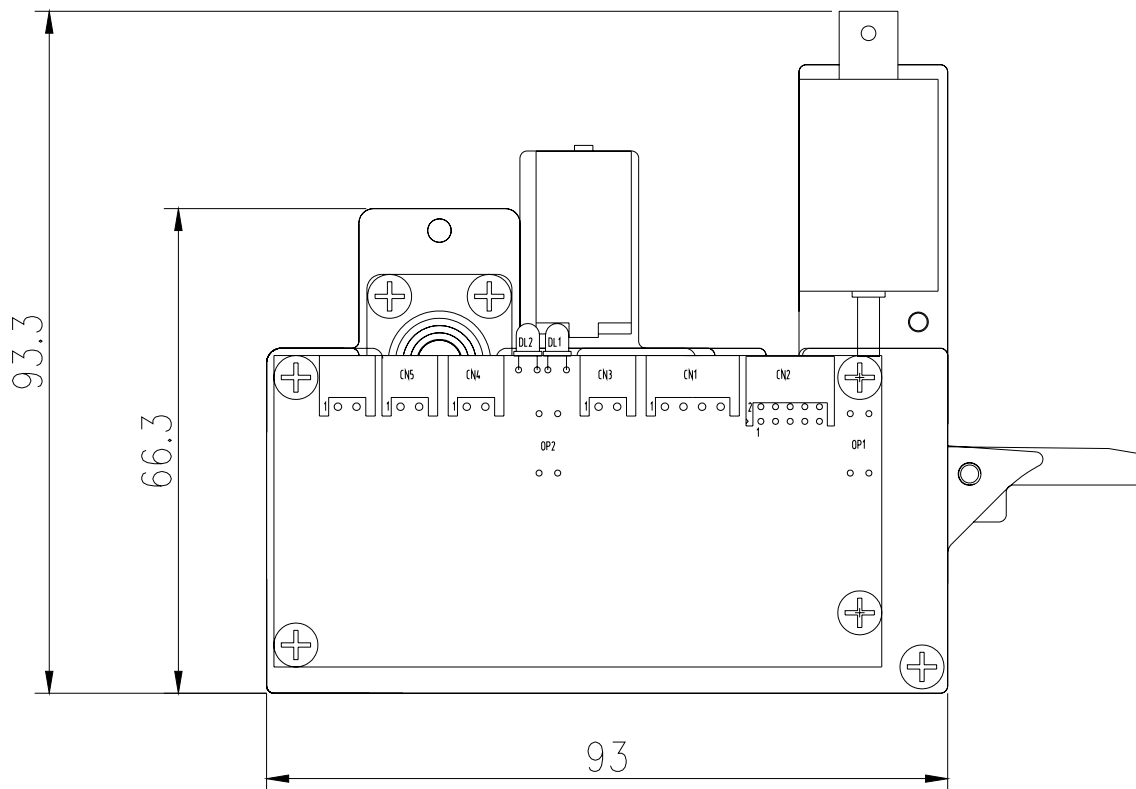

5 DIMENSIONS ENC899 + OBT_MECH

